

SPEEDBLADE

Speedblade is a type of motorized gate featured with retractable flaps operation principle. Housing materials and light weight cabinets' shape make Speedblade speed gate universal for large variety of facilities with heightened requirements to esthetic equipment appearance. As well as other TiSO speedgates, Speedblade has implemented anti-tailgating and other safety and security functions. Normal and wide lanes for disabled people can be arranged through cabinets with the same sizes. Speed gates can be operated from a remote control panel or via access control system.



MOTORIZED SPEED GATES FEATURED WITH RETRACTABLE GLASS LEAVES



Key features:

- BMDrive® - a reliable mechanism with a powerful BLDC gear motor ensures long term maintenance-free operation.
- Speed gate equipped with a smart self-diagnosing system.
- Innovative controller with OLED display and buttons for easy setup and configuration without special programmers.
- Digital control of force and leaf speed in combination with safety sensors prevent a person from being struck by a leaf, even in case of an unauthorized passage.
- Sensor system allows detecting the passage of a person with luggage, or arranging a free exit without the need for identification.
- Elegant cabinets equipped with integrated LED lighting showing access status and card reader area.
- Same dimensions of cabinet for normal (550 mm) and wide lane (900 mm).
- The ability to customize housing design and top lid.
- Low power consumption.
- Can be integrated with any type of access control systems.
- Wired remote control panel in standard kit.
- In case of power failure, leaves could be opened manually (fail-safe).

*optional

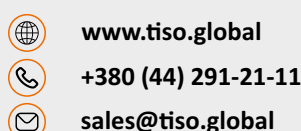

TECHNICAL SPECIFICATIONS /

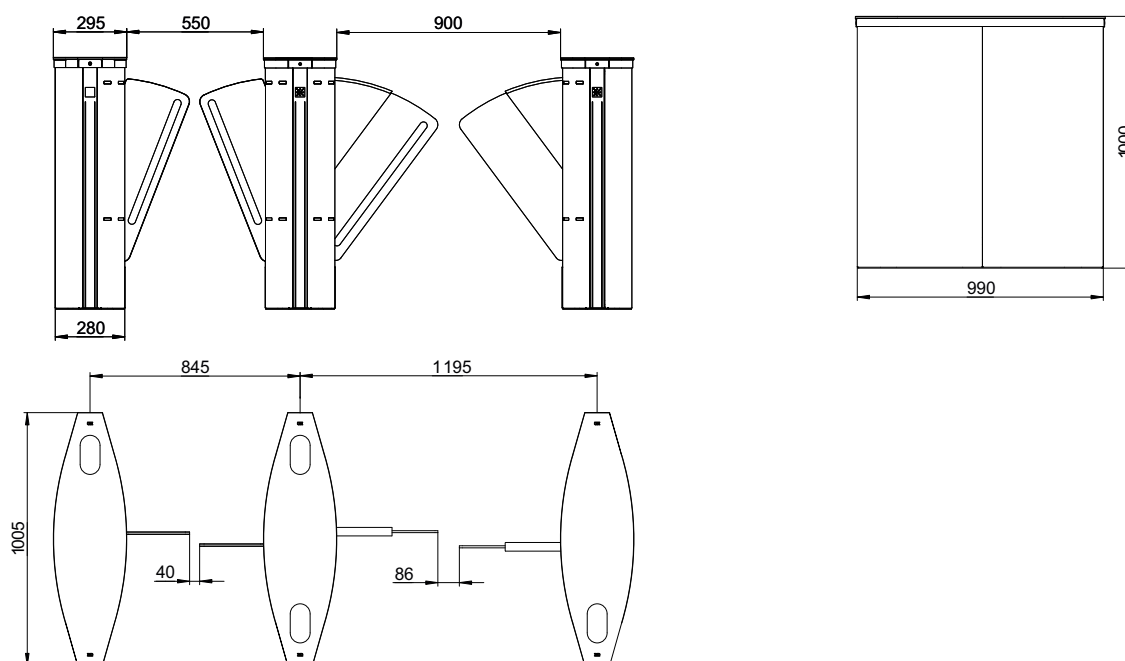

| Model | Speedblade 550 | Speedblade 900 |
|-----------------------------------|--|----------------|
| Cabinet width, mm | | 295 |
| Cabinet length, mm | | 1005 |
| Cabinet height, mm | | 1000 |
| Passage width, mm | 550 | 900 |
| Opening/closing time, sec | 0,5 | 0,8 |
| Mechanism | BMDrive® servodrive (BLDC) | |
| Blocking system | DeadLock® | |
| Emergency mode (fire-alarm) | Free entry/exit (leaves are opened automatically) | |
| Power fail | Fail safe (gates could be opened manually — standard) | |
| MCBF, cycles | 10 000 000 | |
| MTTR, min | < 25 | |
| Electrical Specifications: | | |
| Maximum power consumption, W | 160 | |
| Voltage | From the AC (100-240)V, 50/60Hz; from a DC source 12 V | |
| Indication | DotLights®, RFIDLights®, LeafLights® | |
| Finishing | | |
| Standard housing | Brushed SS AISI 304 | |
| Available housing | Brushed SS AISI 316; Polished SS AISI 304; Polished SS AISI 316; Powder coated RAL | |



Dimensions for solid glass top lid

Specifications are subject to change without prior notice



 www.tiso.global
 +380 (44) 291-21-11
 sales@tiso.global



STANDARD FEATURES

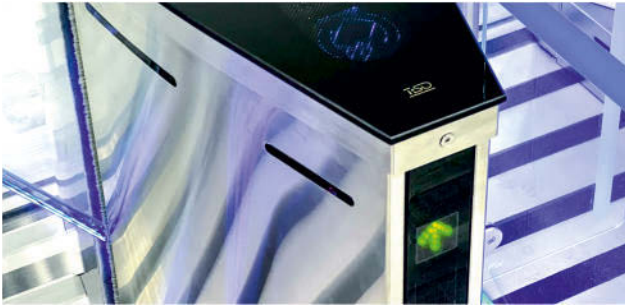

LED INDICATIONS

Introducing our RFIDLight® and DotLight® features, designed to captivate attention and enhance user experience:

RFIDLight®: Illuminates card reader area.
DotLight®: Displays access status.



CONTROL PANEL

Included in the standard set, our wired control panel offers versatile functionality: Facilitates single passage and free passage modes. Enables access blocking and activation of the anti-panic function.

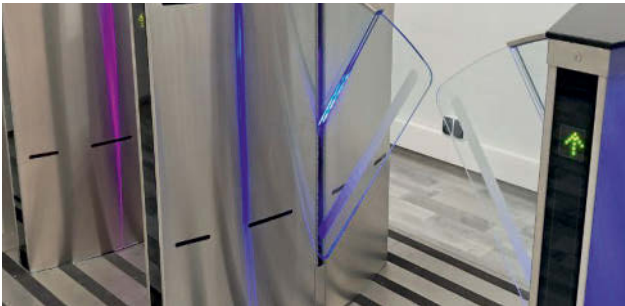

SAFETY SENSORS, ANTI-TAILGATING FUNCTION

Our high-precision sensors excel in identifying unauthorized passage, effectively preventing tailgating by detecting two or more individuals. Additionally, our safety sensors ensure secure passage for individuals with luggage or trolleys, ensuring gates remain open until the passage is completed.

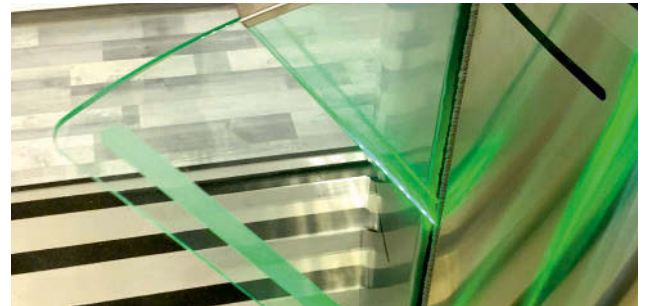

LEAFLIGHT®

Experience the striking illumination of our leaves, available in three standard colors to signify passage status:

- Blue: For standby mode.
- Green: Signifying access authorization.
- Red: Denoting access denial.
- Custom colors are also available upon request.



UPS FUNCTION

Introducing our advanced UPS system, seamlessly integrated to automatically switch power to the backup battery during outages. This ensures uninterrupted functionality of our speed gate, empowering you to utilize all features even in the event of a power failure.

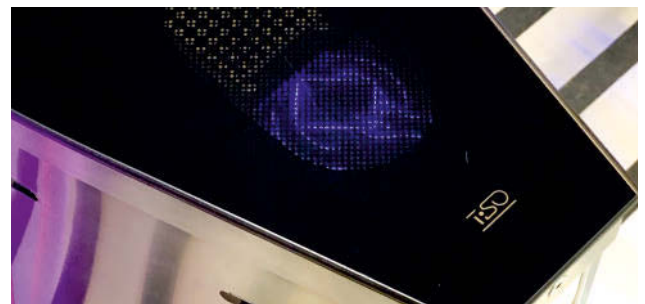

PLACE FOR RFID INSTALLATION

RFID installation space included in standard speedgate configuration.

ADDITIONAL OPTIONS /

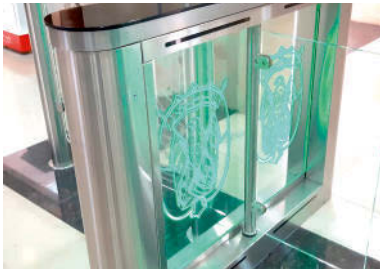

PATTERN APPLICATION

Customize your speed gates with unique signatures, patterns, logos, and more, seamlessly placed on the leaves, housing, or top lid for a distinctive touch.



MP3 AUDIO MODULE

Enjoy a comprehensive audio signaling system for various gate events: access / authorised access / closing / opening / alarm.

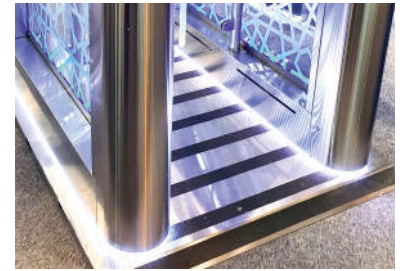

FOOTPRINT ILLUMINATION

Illuminate the footprint of the speed gate housing with LED lighting. Customize the color of the light to suit your preferences.



INTEGRATION OF CUSTOMISED ACS

Seamless integration of various access control systems upon request, including RFID devices, coin acceptor push buttons, fingerprint scanners, face recognition, barcode readers, and QR code readers.



TWIC WIRELESS CONTROL PANEL

TiSO TWIC offers remote control for multiple lines of turnstiles. With its space-saving 10" touchscreen display, it can be conveniently placed at reception desks or within security control areas.



SUPER CAPASITOR

Ensure uninterrupted operation with our free power package, enabling emergency automatic one-time opening of the speed gate.



CARD COLLECTOR INTEGRATION

Integration of automatic card collector directly into the speed gate housing is possible.



PASS COUNTER

Automatically counts the number of passes for efficient tracking and management.



EXIT BUTTON

Introducing a convenient touch-free button option for organizing exits effortlessly.

ADDITIONAL OPTIONS /

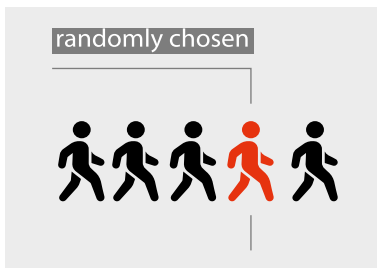

RANDOMISER

This mechanism autonomously selects individuals for verification without human intervention, ensuring impartiality.



RFID READERS T-PROX MINI

The reader is compatible with 125 kHz cards, Mifare, Mifare Plus, as well as mobile credentials U-Prox ID via NFC and 2.4 GHz radio.

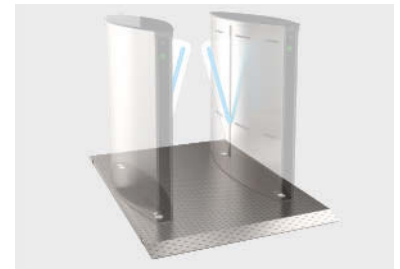

MOBILE PLATFORM

Enables rapid temporary installation of the speed gate, ideal for areas where floor drilling is not possible.



JUMPING OVER TOP LEAD ALARM

Weight sensors detect impacts over 10 kg on the top lid and trigger an alarm.

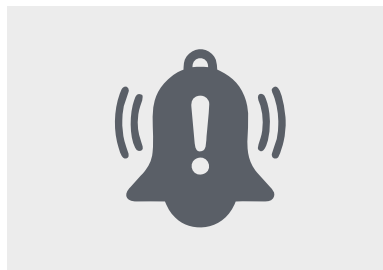

ALARM BUZZER

Audible alarm activated upon unauthorized access.