

SWEEPER-AL

SPEED GATES

Sweeper AL – speed gate system based on Sweeper and Sweeper-HG models combination with swing type flaps and a reliable mechanism with a brushless motor. The construction of the system allows to arrange two checkpoints for access verification.

Possibility of various biometric devices integration along with various glass height options at every checkpoint (overall height could be 1000-1800 mm) provide maximum security control during passage of people through the gate to protected area.





ELEGANT ACCESS SOLUTIONS WITH TWO-STAGE IDENTIFICATION SYSTEM



Key features:

- BMDrive[®] - Sweeper AL is equipped with BM drive (a reliable mechanism with powerful a brushless motor), which provides long-term maintenance-free and trouble-free operation.
- The innovative motor controller with an OLED display and buttons for easy setup and configuration without special programmers.
- The sweeper AL smart self-diagnostic system automatically detects critical malfunctions, and records error log and warnings.
- Digital control of force and leaf speed, combined with safety sensors, prevents accidents and ensures the safety of individuals, even in cases of unauthorized passage.
- The safety sensors system allows detecting the passage of a person with luggage, or arranging a free exit without necessity of identification.
- Ability to arrange two checkpoints for access verification.
- Elegant cabinets are equipped with integrated LED lighting to display access status and card reader area.
- The same dimensions of cabinet for normal (550 mm) and wide lane (900 mm).
- The ability to customize cabinet and top lid design as per project requirements.
- Low power consumption.
- Sweeper AL supplied with wired push button by default.
- Availability of integration with any access control system.



 www.tiso.global
 +380 (44) 291-21-11
 sales@tiso.global



TECHNICAL SPECIFICATIONS/

Model	Sweeper-AL	
Cabinet width, mm	208	
Cabinet length, mm	2663	
Cabinet height, mm	1010	
Leaves height, mm	1520/1800	
Passage width, mm	550	900
Opening/closing time, sec	1,2	1,8
Mechanism	Servo-driven (Motorized)	
Emergency mode (fire-alarm)	Free entry/exit (leaves are opened automatically)	
Power fail	Fail safe (gates could be opened manually — standard)	
MTTR, min	< 25	

Electrical Specifications:

Maximum power consumption, W	310	
Voltage	From the AC (100-240)V, 50/60Hz; from a DC source 12 V	
Indication	DotLights®, RFIDLights®, EdgeLights®	

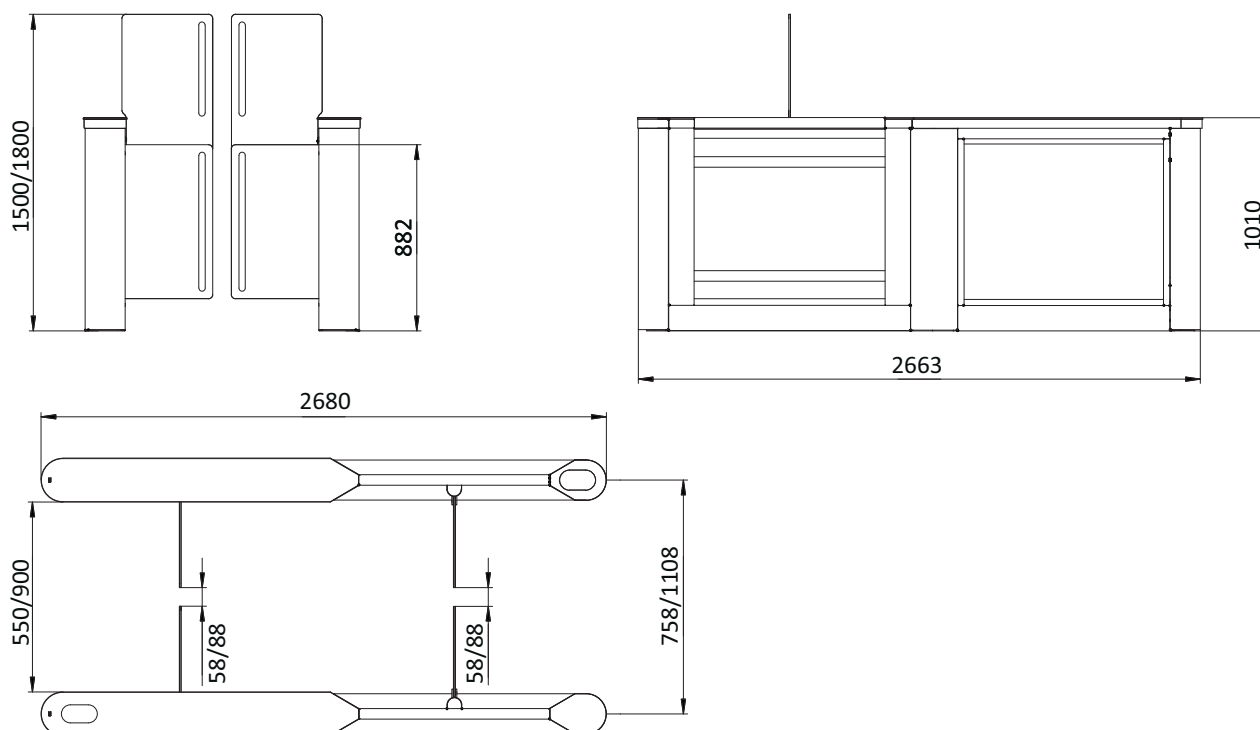

Finishing

Standard housing	Brushed SS AISI 304	
Available housing	Brushed SS AISI 316; Polished SS AISI 304; Polished SS AISI 316; Powder coated RAL	



Specifications are subject to change without prior notice



 www.tiso.global
 +380 (44) 291-21-11
 sales@tiso.global



STANDARD FEATURES



LED INDICATIONS

Introducing our RFIDLight® and DotLight® features, designed to captivate attention and enhance user experience:

RFIDLight®: Illuminates card reader area.
DotLight®: Displays access status.



CONTROL PANEL

Included in the standard set, our wired control panel offers versatile functionality: Facilitates single passage and free passage modes. Enables access blocking and activation of the anti-panic function.



SAFETY SENSORS, ANTI-TAILGATING FUNCTION

Our high-precision sensors excel in identifying unauthorized passage, effectively preventing tailgating by detecting two or more individuals. Additionally, our safety sensors ensure secure passage for individuals with luggage or trolleys, ensuring gates remain open until the passage is completed.



UPS FUNCTION

Introducing our advanced UPS system, seamlessly integrated to automatically switch power to the backup battery during outages. This ensures uninterrupted functionality of our speed gate, empowering you to utilize all features even in the event of a power failure.



EDGE LIGHTS®

Impressive illumination of the glass housing can be in three colors (standard), marking the status of passage: blue - standby mode; green - access authorized; red - access denied.



PLACE FOR RFID INSTALLATION

RFID installation space included in standard speedgate configuration.



www.tiso.global

+380 (44) 291-21-11

sales@tiso.global



ADDITIONAL OPTIONS /

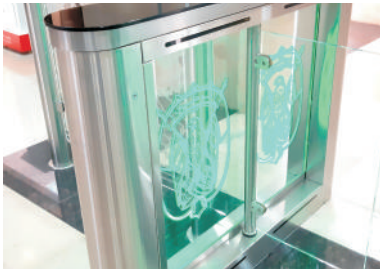

PATTERN APPLICATION

Customize your speed gates with unique signatures, patterns, logos, and more, seamlessly placed on the leaves, housing, or top lid for a distinctive touch.



MP3 AUDIO MODULE

Enjoy a comprehensive audio signaling system for various gate events: access / authorised access / closing / opening / alarm.

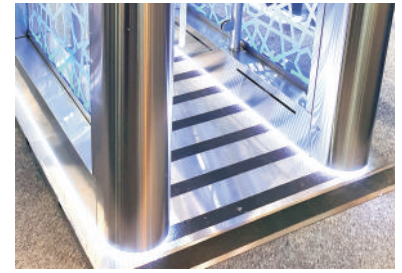

FOOTPRINT ILLUMINATION

Illuminate the footprint of the speed gate housing with LED lighting. Customize the color of the light to suit your preferences.



INTEGRATION OF CUSTOMISED ACS

Seamless integration of various access control systems upon request, including RFID devices, coin acceptor push buttons, fingerprint scanners, face recognition, barcode readers, and QR code readers.

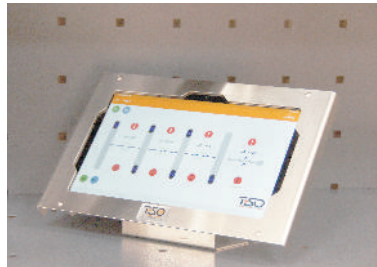

TWIC WIRELESS CONTROL PANEL

TiSO TWIC offers remote control for multiple lines of turnstiles. With its space-saving 10" touchscreen display, it can be conveniently placed at reception desks or within security control areas.



SUPER CAPASITOR

Ensure uninterrupted operation with our free power package, enabling emergency automatic one-time opening of the speed gate.



CARD COLLECTOR INTEGRATION

Integration of automatic card collector directly into the speed gate housing is possible.



PASS COUNTER

Automatically counts the number of passes for efficient tracking and management.



EXIT BUTTON

Introducing a convenient touch-free button option for organizing exits effortlessly.

ADDITIONAL OPTIONS /

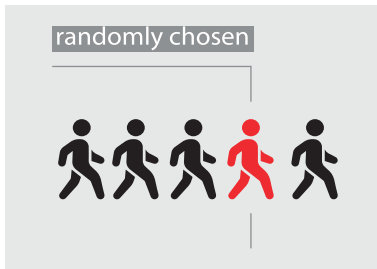

RANDOMISER

This mechanism autonomously selects individuals for verification without human intervention, ensuring impartiality.



RFID READERS T-PROX MINI

The reader is compatible with 125 kHz cards, Mifare, Mifare Plus, as well as mobile credentials U-Prox ID via NFC and 2.4 GHz radio.

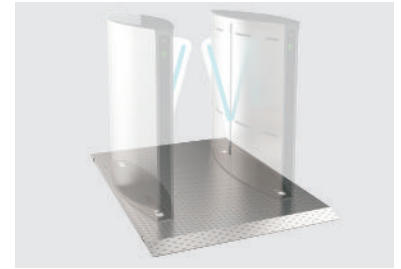

MOBILE PLATFORM

Enables rapid temporary installation of the speed gate, ideal for areas where floor drilling is not possible.



JUMPING OVER TOP LEAD ALARM

Weight sensors detect impacts over 10 kg on the top lid and trigger an alarm.



ALARM BUZZER

Audible alarm activated upon unauthorized access.